







1. Write the name of each shape. Use the English names: *triangle*, *rhombus*, *parallelogram*, *rectangle*, *square*, *trapezoid*, *circle*, *hexagon*.

	English	Polish
		
		
		
		
		
		
		

2. Find the value of x, y and z:



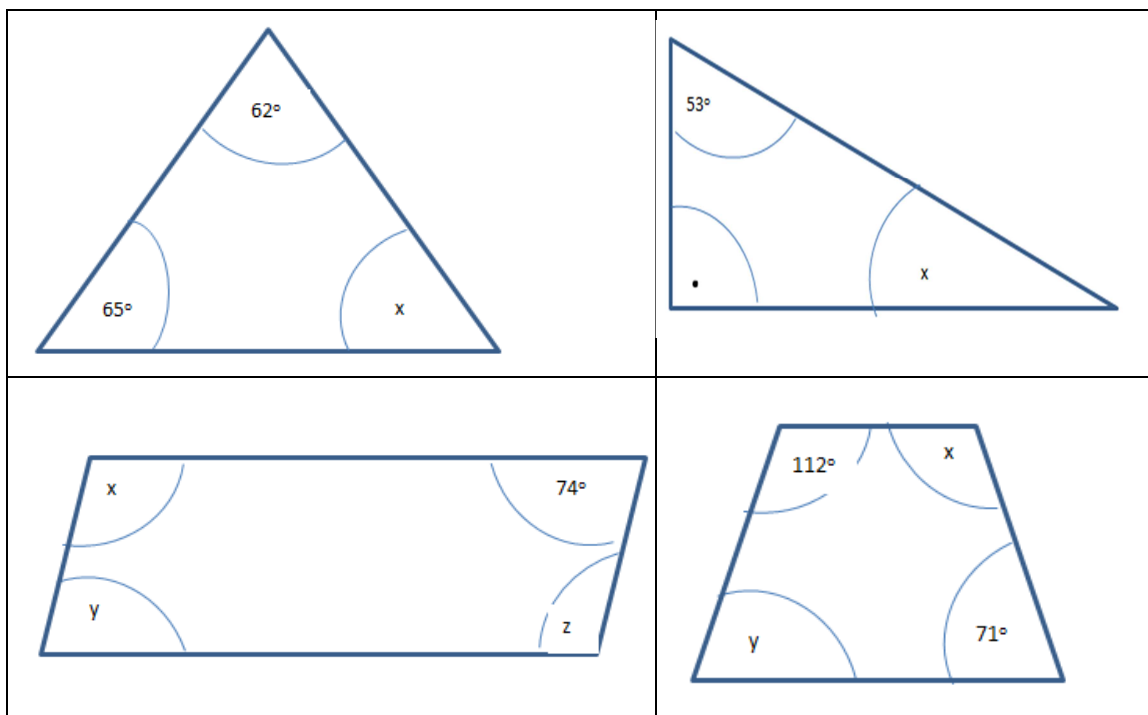
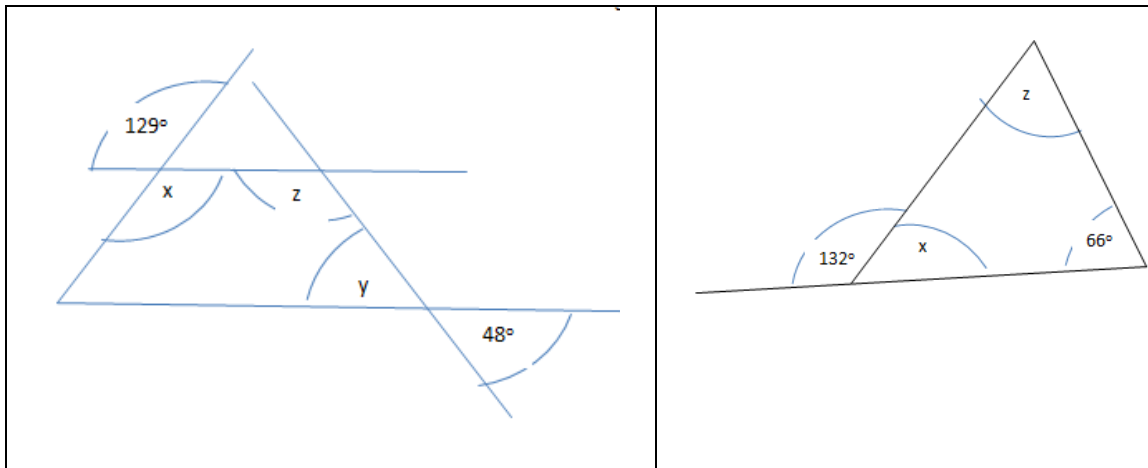

3. What is perimeter of each shape?

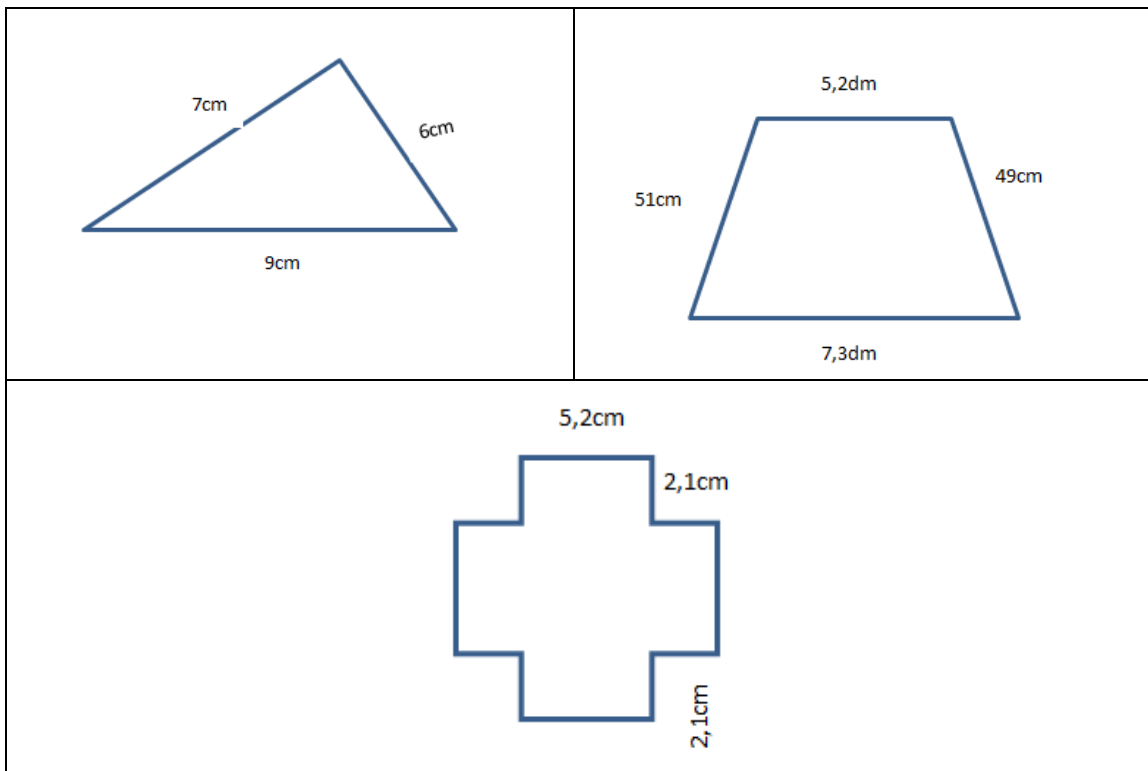

4. Complete the table for each rectangle:

length	width	area
7m	3m	
15dm		45dm ²
6cm	1,2dm	
32mm	2,5cm	

5. A square has area 49cm². What is the length of its side?